



BLENDING STATION® ADVANCE®

The Right Blend of Timing and Speed

The Blending Station Advance has been engineered for perfection including a noise reducing cover for an improved customer experience.

Smart Product Design

- Powerful ≈ 3 peak output HP motor for unmatched performance for the toughest blends in coffee, smoothie, and ice cream shops
- 93 speeds, a variable speed control, and automatic shut-off provide the ultimate in blending flexibility and creating endless number of recipes to expand your menu offering
- 34 optimized programs engineered to provide consistent results quickly and easily
- The Advance® container creates faster, smoother pouring without the mess saving you time and money



Creamy, blended coffee drinks

Product Specifications

Blending Station® Advance®

On-Counter: Item No. 50029 / In-Counter: Item No. 51022

Motor: ≈3 peak output horsepower motor

Electrical: 220-240 V, 50/60 Hz, 1300-1550 W

Pack: Includes Blending Station Advance® with 1,4 L high-impact, clear/stackable Advance container, complete with blade assembly and lid, and removeable compact cover*.

Net Weight: 7,7 kg (8,6 kg with box)

Dimensions:

On-Counter: 49,2 x 23,5 x 26,7 cm (H x W x D)
Height with lid open: 68,9 cm

In-Counter: 38,1 x 22,9 x 26,7 cm (H x W x D)
Height with lid open: 68,9 cm
Depth below counter: 14,4 cm

* Standard 2,0 L container cannot be used with the compact cover.

Warranty: Please contact your authorized Vitamix distributor for warranty information.

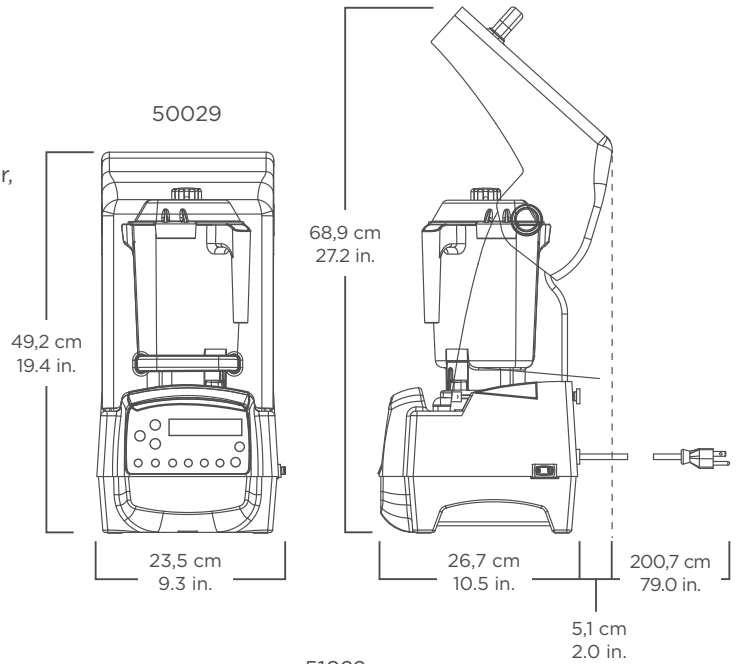

Also Available

Blending Station Advance On-Counter with Advance container

Item No. 36208: 120 V (EMC), 50/60 Hz, 15 A

Item No. 52004: 100 V, 50/60 Hz, 1500 W

Blending Station Advance In-Counter with Advance container

Item No. 53004: 100 V (EMC), 50/60 Hz, 1500 W

Additional containers, complete with blade assembly and lid.

Item No. 15978: Advance container 1,4 L

Item No. 15506: standard container 1,4 L

Item No. 15640: compact container 0,9 L

For more information, please contact an authorized Vitamix distributor, or Vitamix international customer service.

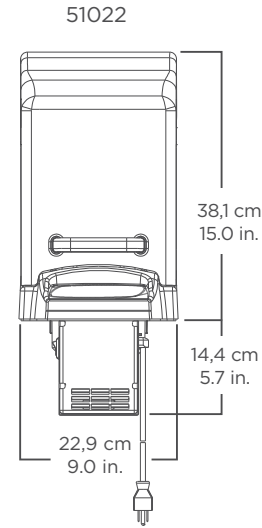

Contact Information

U.S.A., Canada & Latin America:

Tel: 800.4DRINK4 or
440.235.0214

E-mail: foodservice@vitamix.com

www.vitamix.com/foodservice

Vita-Mix Corporation
8615 Usher Road
Cleveland, OH 44138-2103 U.S.A.

Outside of U.S.A., Canada &
Latin America:

Tel: +1.440.782.2450

E-mail: international@vitamix.com

For more information, contact your
local foodservice distributor.